

()
INTERSTATE COUNCIL FOR STANDARDIZATION, METROLOGY AND CERTIFICATION
(ISC)

**32396-
2021**

-

2021

1.0 «
 1.2 «
 »
 1 « » (« »)
 2
 3
 (26 2021 . 142-)

(3166) 004—97	(3166) 004—97	
	BY KZ KG RU UZ	« »

4 12
 2021 . 1123- 32396—2021
 1 2022 .

5 32396—2013

()
 ,
 ,
 ,
 « »



IEC
TN-S TN-C-S 30331.1
()
I.
IEC 61439-3.
IEC 61439-3
IEC 61439-1
IEC 61439-3
12.2.007.0.
I II
(TN-C)
/ /
IEC 61439-3
()
I II
IEC 61439-1

32396—2021

-

-

— 2021—10—01

		TJ

(2022 .)

Input-distributional boards for dwellings and public buildings. General specifications

— 2022—03—01

1

- 1.1 (), -
- 1.2 230/400 50—60 -
- 1.3 ,
- 1.4 — 4 15150 15543.1. -
- 1.5 6.2.11,6.2.14, 6.2.21,6.3.12,
- 1.6 IEC 61439-1
- IEC 61439-3.

2

- 2.601¹⁾
- 9.032 ,
- 9.302 -
- 9.303 -
- 9.401 .
- 9.410 .

¹⁾ 2.601—2019 « ».

32396—2021

12.1.004—91	.	.	.	-
12.2.007.0	.	.	.	-
12.4.026	.	.	.	-
27.003	.	.	.	-
27.410 ¹⁾	.	.	.	-
4751	.	.	.	-
10434	.	.	.	-
13716	.	.	.	-
14192	.	.	.	-
14254 (IEC 60529:2013)	.	.	(IP)	-
15140	.	.	.	-
15150	.	.	.	-
15543.1	.	.	.	-
16962.1 (68-2-1—74)	.	.	.	-
16962.2	.	.	.	-
17516.1	.	.	.	-
18690	.	.	.	-
21130	.	.	.	-
21991 (447-74)	.	.	.	-
23216	.	.	.	-
30331.1 (IEC 60364-1:2005)	.	.	1.	-
30331.3 (364-4-41—92) ²⁾	.	.	3.	-
30331.10 (364-5-54—80) ³⁾	.	.	5.	-
54.	.	.	.	-
IEC 60695-2-11	.	.	2-11.	-
IEC 60900	.	.	.	-
1000 1500	.	.	.	-

27.403—2009 «

».

²⁾

4-41.

50571.3—2009 (60364-4-41:2005) «

».

³⁾

5-54.

50571.5.54—2013/ 60364-5-54:2011 «

».

- IEC 60947-1 1. -
- IEC 61439-1—2013
- 1. IEC 61439-3 3.
- IEC 62262 -
- (IK) -

(www.easc.by)

3

3.1

3.1.1 ; :

()

3.2.

3.1.2 : (-)

1 , 3.1.1.

2

3.1.3 : ()

3.1.4 ; :

3.1.5 :

3.1.6 :

3.1.7

3.2

3.2.1

3.2.2

3.2.3

3.3

3.3.1

3.3.2

()

3.3.3

3.3.4

()

3.3.5

3.4

3.4.1

3.4.2

[IEC 61439-1—2013, 3.4.5]

3.4.3

3.4.4

3.4.5

() (),

3.4.6

),

IP

14254.

3.4.7 : ,

3.4.8 : (),

3.4.9 : , N

— « »

3.5 ,

3.5.1 : -

3.5.2 : / -

() : -

3.5.3 : -

()

3.5.4 ; /- : -

[IEC 61439-1—2013, 3.7.6]

3.5.5

N: ,

[IEC 61439-1—2013, 3.7.5]

3.5.6

: , -

[IEC 61439-1—2013, 3.7.4]

3.6 ,

3.6.1 : -

().

3.6.2 : -

—

3.6.3 : -

—

3.6.4 : -

—

3.6.5 : , -

3.6.6 : , -

[IEC 61439-1—2013, 3.8.10.1]

3.6.7 : , -

[IEC 61439-1—2013, 3.8.10.2]

3.6.8 I_{cw} (): -

[IEC 61439-1—2013, 3.8.10.3]

3.6.9 I : -

(), -

[IEC 61439-1—2013, 3.8.10.4]

4

1.

1—

1 :	+	+	-
-	+	+	+
2 :	+	+	+
-	-	-	+
-	-	-	+
3	6.6		
4) (—	1, 2, 4, 6, 7	1, 2, 4, 5, 7	1, 2, 3
5 () 12.2.007.0:			

1

- I	+	+	+
- II	-	-	+
6 (): - -	+ +	+ +	+2) +
7 : - () -	+ +	+ +	+ +
8 : - 1) -	+ -	+ -	+ +
9 / / (: -) / (: - - -	+ +	+ +	+ +

1) (IEC 61439-3).

2)

5

5.1

2.

2—

1 ,	230/400	230/400	230/400
2 ,	250; 400; 630	160; 250	50; 63; 100; 125; 160
3 (),	100; 160; 250; 400	100; 160; 250	—
4 -	5.2		
5 / -	25; 32; 40; 63; 100; 160; 250	25; 32; 40; 63; 100; 160	10; 16; 25; 32; 40

6	10; 16; 25	10; 16; 25	10; 16; 25
7	5.2		
8			300;500
-	300; 500	300; 500	30; 100
-	30	30	10; 30
9	20	15	/,<10
1))			
1)	= 1,5.		

5.2

5.3

2000 800(1200) 500 (, ,), , , -
 — 1000 800 250 .

5.4

6

6.1

6.1.1

6.1.2

1.3.

6.1.3

6.1.3.1—6.1.3.6.

6.1.3.1

1.4.

6.1.3.2

6.1.3.3

— I 15150.

6.1.3.4

15543.1 15150,
 10.

1.4,

6.1.3.5

17516.1.

6.1.3.6

6.1.3.7

(, 2000 .).

6.1.4

50

(,)

- 0,5 /
- 4 / —

();
() 5

6.2

6.2.1

I,

6.2.2

II,

(850 ± 15) °C

— (650 ± 10) °C.

6.2.3

I II,

(960 ± 15) °C

IEC 60695-2-11.

6.2.4

II,

6.2.3

IEC 61439-3.

6.2.5

6.2.6

6.2.7

— 6.6.

6.2.8

6.2.9

6.2.10

(6,),

(7,).

6.2.11

6.2.12

6.2.13

6.2.14

6.2.15) 3.4.4 (

6.2.16 6.2.15 (),

6.2.17 (3.4.6),

6.2.18

6.2.19 I

6.2.20 II II

6.2.19

6.2.21 ()

6.2.22 (—)

6.2.23 -

6.2.24

6.2.25

6.2.26 600 1800 ; — 1000—1800

6.2.27 - (6.2.15).

6.2.28 , 95°

6.2.29

				-
	()	-
6.3.19)		(-
6.3.20		2,5	—	-
6.3.21	1,5			-
6.3.22				-
6.3.23				-
6.3.24				-
6.3.25		IEC 61439-1—2013.		-
6.3.26			(-
6.3.27)			-
6.3.28			450/750	-
6.3.29				-
6.4		L1, L2, L3.		-
6.4.1			(-
6.4.2		10434.		-
6.4.3	1,5		6.3.17 6.3.18.	-
			N	-
				6.4.4.

) , 30331.10. 3;
) 25 2 50 2 30331.10. 3,
 — ;
) 30331.10; 6 25 2 -
) 10 2,
 6.4.4 , N
 , 1,5 2 , -
 3 4,
 , 3 4. -

3—

S, 2	, 2
S < 16	S
16 < S < 35	16
35 < S < 400	S/2
400 < S < 800	200
—	-

4—

N

S, 2	, 2	
S < 16	S	S
S > 16	S/2	S

6.4.5 - /- , -
 6.4.6 -
 6.4.7 - /-
 6.4.8 — 21130. -
 , -
 , -

6.4.9

),

6.8.2.

6.5

6.5.1

2.

6.5.2

6.5.3

6.5.4

21

IEC 60947-1.

6.5.5

2.

6.5.6

2.

6.5.7

:

)

63

)

)]

)

).

6.5.8

6.5.7—

2.

6.5.9

6.5.7

(

4,5

25

, 6

63

10

125

160

6.5.10

2.

6.5.11

6.5.12

2.0.

0,2

0,5.

6.5.13

6.5.14

)

)

)

6.5.15

),)]

6.5.16

6.5.17

6.5.18

6.6

14254

)

-

-

-

)

-

-

)

-

-

— IP00;

() — IP2X;

— IP31, — IP00;

() — IP2XB;

I II

— IP31 (— IP31; — IP20).

IP2XB.

— IP31,

6.2.23

— IP31;

6.2.23

6.7

6.7.1

14254,

6.6,

6.2.

6.7.2

I

6.3.13

6.7.5.

6.8.2.

IEC 61439-1—2013.

6.7.3

II,

6.7.4

II.

6.7.5

(/,)-

6.7.2

0,1

6.7.6

6.7.7

6.7.8

«

6.7.9

21991.

6.7.10

II

U=U,

6.7.11

6.7.12

«

!

»

(. 6.2.23, 6.2.24)
12.4.026.

6.7.13

-

;

-

-

-

.);

6.7.14

6.8

6.8.1

35 °C

5.

5—

, °C

		35 ° 1>
1	:	

		35 °C ¹⁾	
-		55	90
-	²⁾	70	105
2	()	55	90
3		35	70 ³⁾
4		25	60
5	:		
-		30	65
-		35	70
¹⁾ , 35 °C, ²⁾ , 105 °C, ³⁾			

6.8.2

2.

N

60 %

2.

— 0,2 .

10 ,

IEC 61439-1.

6.8.3

12 .

— 50 .

1

2

6.8.4

15150

1

2500

50 .

6.8.5

II

1,5

6.8.4 (

3750) .

6.8.6

10 .

6.9

6.9.1

/

6.9.2 9.401, — 9.410.

6.9.3

IV, — VI 9.032.

6.9.4

9.303.

6.9.5

6.10

6.10.1

27.003 27.410.

6.10.2

— 25

6.11

6.11.1

6.11.2

6.11.3

-

-

-

-

-

-

-

-

-

-

-

6.12

6.12.1

6.12.2

-

-

-

-

-

-

-

-

-

-

-

-

-

-

-

-

-

-

-

();

14254;
12.2.007.0;

9,

-
-
-
-
-

6.13

6.14

6.14.1
6.14.2

23216.

6.14.3
6.14.4

6.14.5

6.14.6

6.3.20.
23216

6.14.7

6.14.8

6.2.34.
() .]

[

6.14.9
6.14.10

23216
— 14192.

7

7.1

6.6 6.7.

7.2

6.2.3, 6.2.4,

6.5.4—6.5.9, 6.8.1—6.8.6 12.2.007.0.

7.3

()

10⁻⁶

12.1.004.

8

8.1

8.2

8.2.1

6.

6—

	()	
1	6.2.27, 6.2.28	9.9
2	6.3.15	9.14
3	- « » « /» -	6.3.16 9.15
4	6.3.20	9.16
5	450/750	6.3.28 9.17
6	6.3.29	9.18
7	6.4.6	9.19
8	6.4.7	9.20
9	6.5.16—6.5.18	9.22
10	-	6.7.5 9.24
11	-	6.7.8, 6.7.9 9.25
12	II	6.7.10 9.26
13		6.7.11 9.27
14		6.7.12 9.28
15		6.8.6 9.33
16		6.9.2, 6.9.3 9.34
17		6.9.4 9.35
18		6.11 9.37
19		6.12.1, 6.12.2 9.38
20		6.7.6, 6.13 9.39
21		6.14 9.40
— - -		

6.9.4

6.9.2 6.9.3,

() ,

8.2.2

8.2.3

8.2.4

8.3

8.3.1

7.

7—

			()	
	-	-		
1	+	-	5.3	9.1
2	+	+	6.2.1, 6.2.5—6.2.28, 6.2.29-6.2.31, 6.2.33—6.2.35, 6.2.38, 6.3.1—6.3.10, 6.3.12—6.3.14, 6.3.17—6.3.19, 6.3.21—6.3.25, 6.4.1,6.4.5, 6.4.8, 6.4.9, 6.7.1—6.7.4, 6.7.13, 6.7.14	9.2
3	+	-	6.4.2—6.4.4	9.3
4	+	-	6.1.3.4	9.4
5	+	-	6.1.3.5	9.5
6	+	-	6.2.2, 6.2.3	9.6
7	+	-	6.2.4	9.8
8	+	-	6.2.32	9.10
9	+	-	6.2.36	9.11
10	+	-	6.2.37	9.12
11	+	-	6.2.38—6.2.40	9.13
12	+	+	6.5.1—6.5.15, 6.7.7	9.21
13	+	+	6.6	9.23
14	+	+	6.8.1	9.29
15	+	+	6.7.2, 6.8.2	9.30

7

			()	
	-	-		
16	+	+	6.8.3	9.31
17	+	+	6.8.4, 6.8.5	9.32
18	+	-	6.10	9.36
19 ()	+	-	7.3	9.41

— «+» , «-» — .

8.3.2 -

8.3.3 (6.2.2, 6.2.3, 7.3 6.2.4) 8.3.4 8.3.3 7, - 1,2,3,12,9,10,11,8,4, 5, — 16, 17, 14, 15, 13, 18. 9 7 - - (. 2).

8.3.5 8.3.4 -

8.3.6 7. (6, 7 7) - (I II. -

II) — IEC 60695-2-11, -

IEC 61439-3. 8.3.7 8.3.4, 8.3.6 -

8.3.8 (18 19 7), — -

— 9.41 -

8.4

8.4.1 -

8.4.2 (/ , — 8.3.2) ,

8.4.3 7. -

8.4.4 7: 2, 12, 16, 17, 14, 15, 13. -

8.4.5					-	
8.4.6	7.				-	
8.5						
8.5.1					-	
8.5.2			7.		-	
8.5.3					-	
9						
9.1		5.3			-	
9.2				6.2.1, 6.2.5—6.2.28, 6.2.29—6.2.31, 6.2.33—6.2.35, 6.2.38, 6.3.1—6.3.10, 6.3.12—6.3.14, 6.3.17—6.3.19, 6.3.21—6.3.25, 6.4.1, 6.4.5, 6.4.8, 6.4.9, 6.7.1—6.7.4, 6.7.13, 6.7.14		-
9.3					-	
6.4.2—6.4.4					-	
9.4				6.1.3.4	-	
	16962.1.					
9.5				6.1.3.5	-	
	16962.2.					
9.6				6.2.2	-	
	6.1.3,				-	
		IEC 60695-2-11.				
		—	IEC 60695-2-11.			
		—	6.2.2 6.2.3.			
				15150.		
9.7			—	IEC 60695-2-11.	-	
1				II	-	
2					-	
	(
9.8					-	
		6.2.4		II	-	
		I II,		IEC 61439-3.	-	
9.9				6.2.27 6.2.28	-	

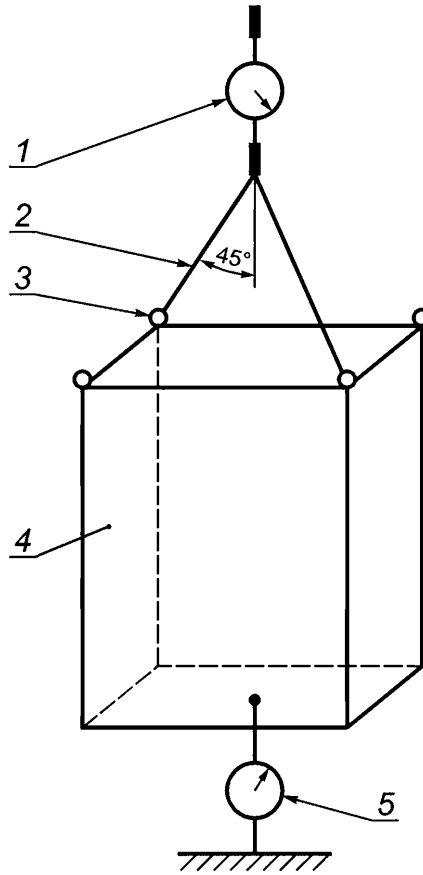

1— ; 1;2— ; 3— ; 4— ; 5— 2
1

— 10 .

1
2
9.14 6.3.15 -
(,).
9.15 « » « /»
6.3.16
9.16 6.3.20
9.17 450/750 6.3.28
18690.
9.18
6.3.29
9.19 6.4.6 -
-

9.20					-
6.4.7					-
9.21					-
6.5.1—6.5.15, 6.7.7					-
9.22			6.5.16		-
	6.5.17	—			6.5.18 —
9.23			6.6	14254.	
		—	14254.		
9.24				6.7.5	-
					-
9.25				6.7.8	-
«	»	«	».		-
					-
	6.7.9				-
		21991.			-
9.26			II	6.7.10	-
9.27					-
(,)			-
9.28					-
6.7.12					-
9.29				6.8.1	-
9.29.1					-
		15150.			-
9.29.2			(),
					-
	—				-
9.29.3					-
					-
	IEC 61439-1—2013.				-
	—				-
9.29.4				/	-
	—				-
9.29.5					-

			()	-
	5 %,			-
		2 %		-
9.29.6				-
				-
				-
				-
				-
1			()	-
2			<i>N</i>	-
9.29. 7				-
				-
				-
				-
9.29. 8				-
				-
				-
				-
1			()	-
2			<i>N</i>	-
				-
9.29.9		(5—7,)		-
				-
9.29.1 0				-
	9.28.6.			-
9.29.1 1				-
	9.28.5.			-
9.29.1 2			9.28.8	-
				-
				-
9.29.1 3			6.3.1	-
		<i>N</i>	6.3.15,	-
		()		-
9.29.1 4			50 %	-
			— IEC 61439-1,	-
				-
9.29.1 5				-
		5.		-

9.29.1 6

1° / .

9.29.1 7
IEC 61439-1.

9.29.1 8

6.8.1.

6

9.30

9.30.1

6.8.2

9.30.2

9.30.3

)

)

)

)

6.8.2

9.30.4

9.30.5

2

(. 2)

5%.

9.30.6

— 0,2 .

9.30.7

9.30.8

200 °C

160 °C.

9.30.9		3.6.7,							-
	1,05	2,							-
IEC 61439-1.									-
9.30.10					/				-
9.30.11			9.29.10		/	6.8.2.			-
	()	—	/,				-
									N
9.30.12			N			9.29.10,			-
					9.29.8,				-
9.30.13		9.29.8.							-
						6.7.2			-
9.30.14			6.8.2.	9.29.13					-
									-
9.30.15							9.29.13		-
	0,1								-
9.31						6.8.3			-
9.32							6.8.4		-
		6.8.5			IEC 61439-1.				-
9.33			6.3.15.		—	IEC 61439-1.			-
					6.8.6				-
					(6.3.15),		-
							1000		-
9.34						6.9.2	6.9.3 (-
)			9.032	9.410				-
9.35			—	15140.					-
9.36				6.9.4			9.302.		-
				6.10					-
9.37			6.11						-
9.38					6.12.1				-
2.601				6.12.2					-

9.39 6.13, 6.7.6
9.40 6.14
9.41 ()
12.1.004—91 (5).

10

10.1 5 15150,
— 23216. — 2
10.2 15150
10.3

11

11.1 —
11.2 IEC 60900.

12

12.1
12.2 —

()

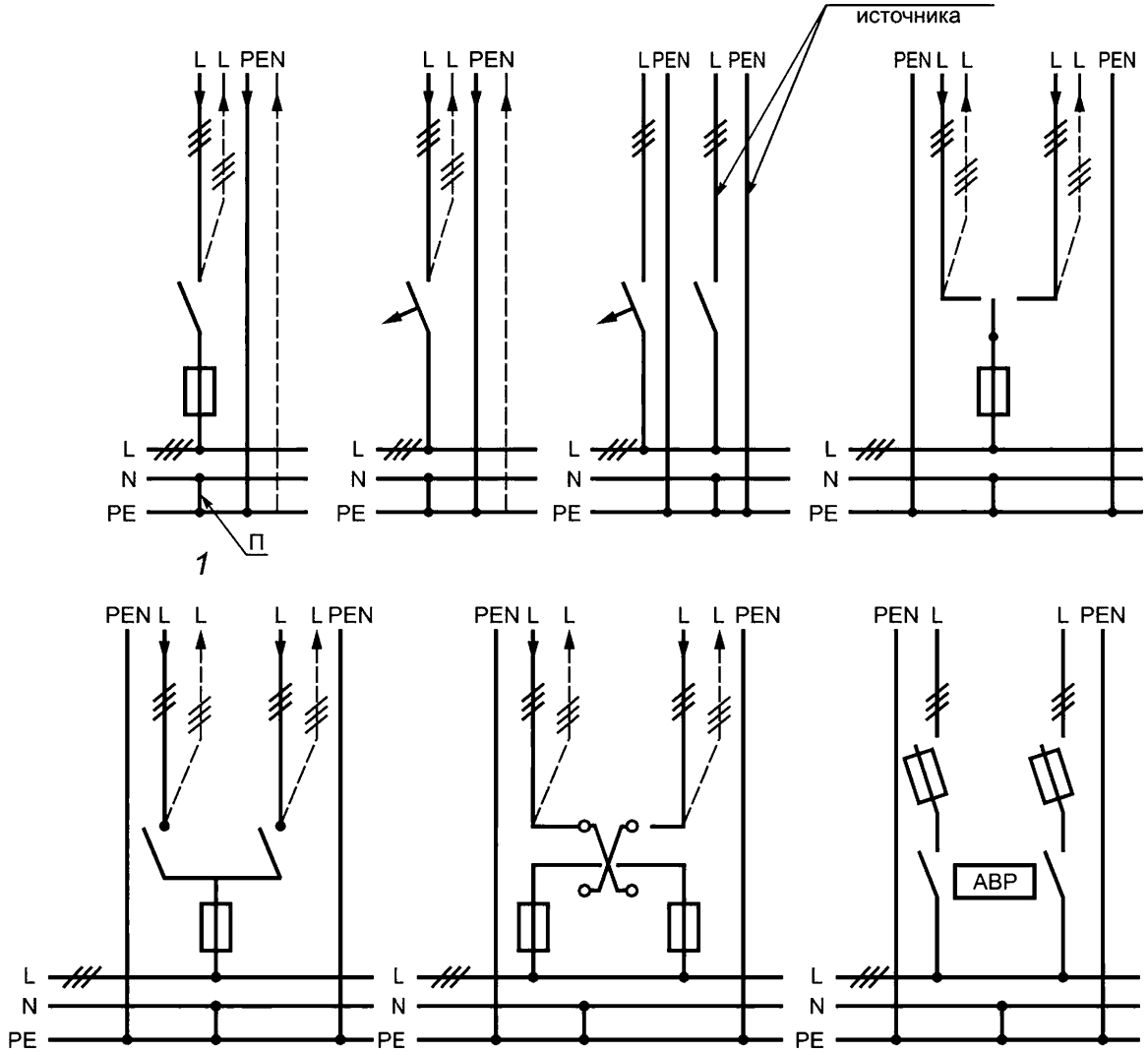

L — ; N — ; — ; — ; PEN —
 — 1—7 — 1.
 .1

7 — TN-C (); 2 — 78 ; 3 — TN-S TN-C-S (.1) .1); 4 — N 6.4.6,
.1); 5 — ; 6 — ; 7 — [. 1) . 16)]
[.1)] / (. 3, 4, 6, 7, 8); 8 — [.1)], ; 9 — ; 70 —
; 10 — ; 72 — (N) ; 77 — (,
13, 14 — N ; 15, 16 — ; 77 — ;
18 — N ; 19 — 6.4.3); 20 — 6.4.36) (
6.4.3); 22 — , ; 27 — 7; 23 —
; 24 — .1, 2

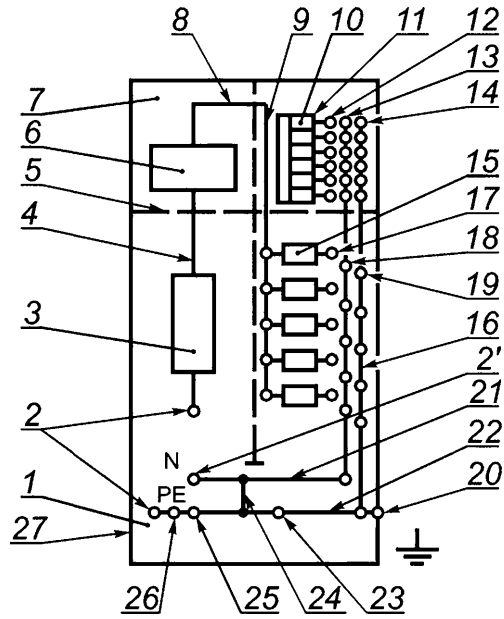

7 — ; 2 — 24 TN-S TN-C-S (); 2' — TN-C (N
 ; 5 — ; 6 — ; 7 — ; 4 — ;
 8 — ; 9 — ; 10 — ; 15 — ; 77 — ;
 ; 72—74 — ; 16 — ; 20 —
 ; 77—19 — 6.4.); 27 — N; 22 —
 ; 23 — ; 24 — 6.4.3);
 ; 25 — 6.4.36) (6.4.3); 27 — () I

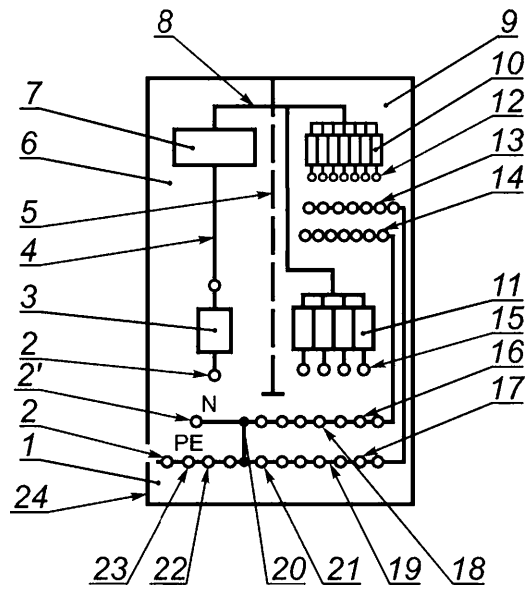

1 — ; 2 —
20
; 5 —
; 10 —
12—14 —
; 18 —

TN-C-S

.4); 2' —
20; 3 —
; 11 —
; 15—17 —
N; 19 —
; 22 —

TN-C [

N
; 9 —
;
; 21 —
6.4.36) (
); 23 —
II

6.4.3); 24 —

) II ()

.4, 1 —

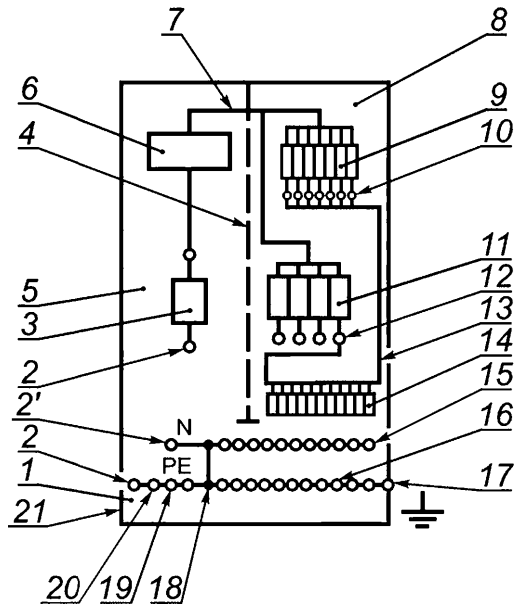

1 — ; 2 — TN-S TN-C-S
 18 — .46); 2'—
 5 — ; 6 — ; 70—
 ; 7 — 9; 77 — ; 8 — ; 9 — ; 72 —
 14; 14 — 70; 13 — 9 77
 ; 15, 16 — N 6.4.5 ,
 19 — ; 77 — ; 18 —
 6.4.36) (
); 20 —
 6.4.3); 27— () I
) I ()
 .4, 2

()

.1 - , - , -

6.3.2 , , () -

.2 6.8.1 , -

. -

1 (7 ,), -

2 , -

(6,), () -

3), .10. (-

.4 () (-

.5) , 2 (-

, ()

(,) .2 (.1 -

[2].

, 6.8.1.

.1

2 3	0,8
4 5	0,7
6 9	0,6
10	0,5

.2

2 3	0,9
4 5	0,8
6 9	0,7
10	0,6

.6	.5	(-
)			6.8.1,
,		6.8.1.	-
	6.8.1,		-
		(-
)	-
.7		3.1.6	-
.8,	3.1.7,		-
(—		-
)		.5, .6.	-
.8		.7	-
.9	.1	.2	-
.10		(. .)	-
.11		6.8.1	-
		.7 .8.	-
(. 6	—		-
) ,			-
.12		/	-
.8,		.5	-
.13		, —	9.29
.14			-
(35 °C,	6.8.1)	6.8.1.
—			-
	25 °C		-
.15			-

16

6.8.1.

6.8.1.

()

.1 (,) -
, .4.

.2 .

1 10.

()

1) , , 2. (-

100 199 200 299,
300 399 400 499.

1 (),

14254,

(I II 12.2.007.0),

2 ()

.4 ()

()

1.4

, 4- , : 360 , 102,
4:

-4 -360-102 4

210,

, 4- , 200 , -
4:

-4 -200-210 4

), — (. . 11 -
, -4 -(120+80) 4.

02- , , 200 , 301,
4:

-02 -200-301 4

003- , , 100 , 405, -
4:

-003 -100-405 4

- [1] IEC 60446:2007 Basic and safety principles for man-machine interface, marking and identification. Identification of conductors by colours or numerals () -
- [2] IEC/TR 60890:2014 A method of temperature-rise verification of low-voltage switchgear and controlgear assemblies by calculation () .

32396—2021

621.316.34:006.354

29.240.30

:

-

-

13.10.2021. 22.10.2021. 60x84%.
. . . 5,58. .- . . 5,02.

« »